



SWD URETHANE

Celebrating 40 years of foam

540 S Drew Mesa, AZ 85210

800-828-1394 swdurethane.com

SWD Urethane Drawings	Drawing number(s)
A. CONTROL JOINT	1
B. EXPANSION JOINT	2
C. FOUNDATION/WALL	3
D. CMU CHANGE IN PLANE	4-1
E. STEEL STUD CHANGE IN PLANE	4-2
F. CHANGE IN SUBSTRATE	5
G. PENETRATIONS	6
H. CMU SUBSTRATE JOINT	7-1
I. STEEL STUD SUBSTRATE JOINT	7-2
J. SUBSTATE JOINT AND DEFECT	8
K. INNER-STORY CONNECTION 1	9-1
L. INNER-STORY CONNECTION 2	9-2
M. WINDOW JAMB	10-1
N. WINDOW HEAD	10-2
O. WINDOW SILL	10-3
P. ROOF/WALL	11

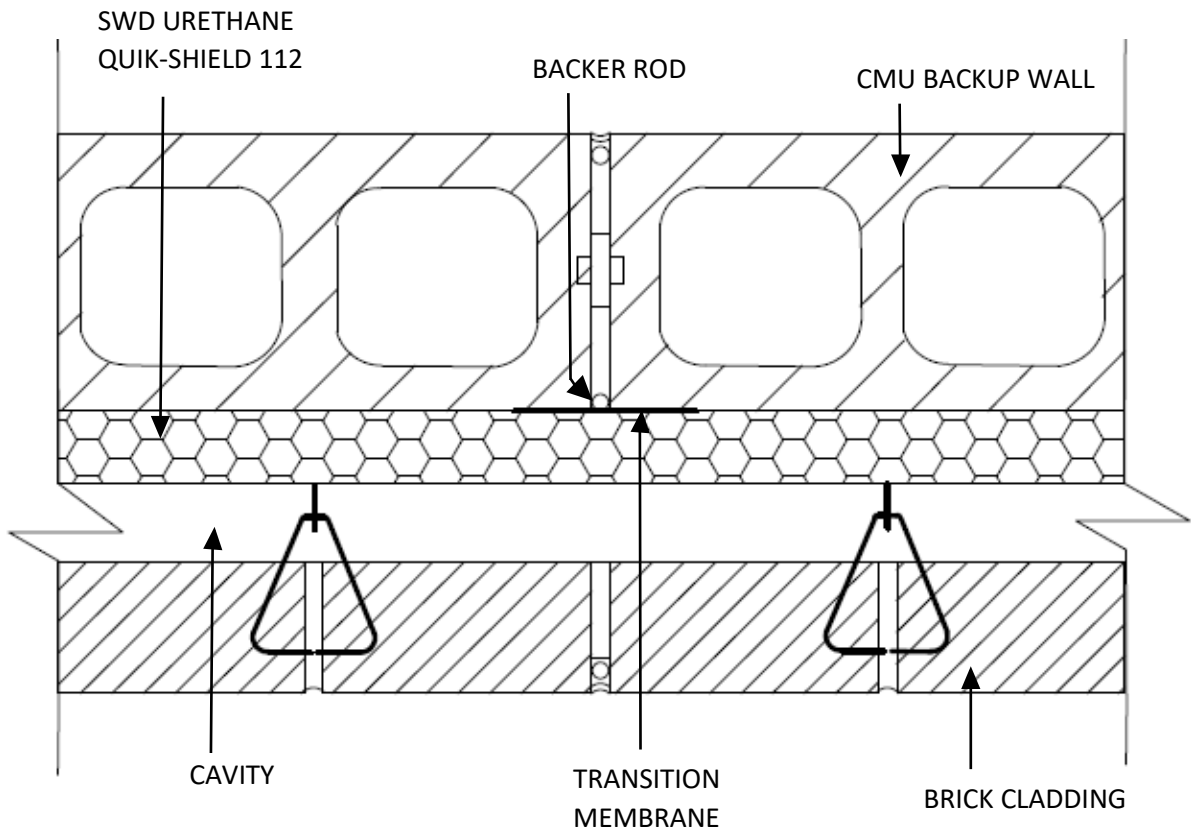

Sketch: CONTROL JOINT	SWD Urethane 540 S Drew St. Mesa, AZ 85210	
Sketch No: 1	Date: 6/25/2018	

*DISCLAIMER – SWD Urethane is not liable for any errors or omissions in design, detail structural capability, attachment details, shop drawings or the like, whether based upon the information provided by SWD Urethane or otherwise, or for any changes which the purchasers, specifiers designers or their appointed representatives may make to SWD Urethane’s published comments. Design details are for reference ONLY.

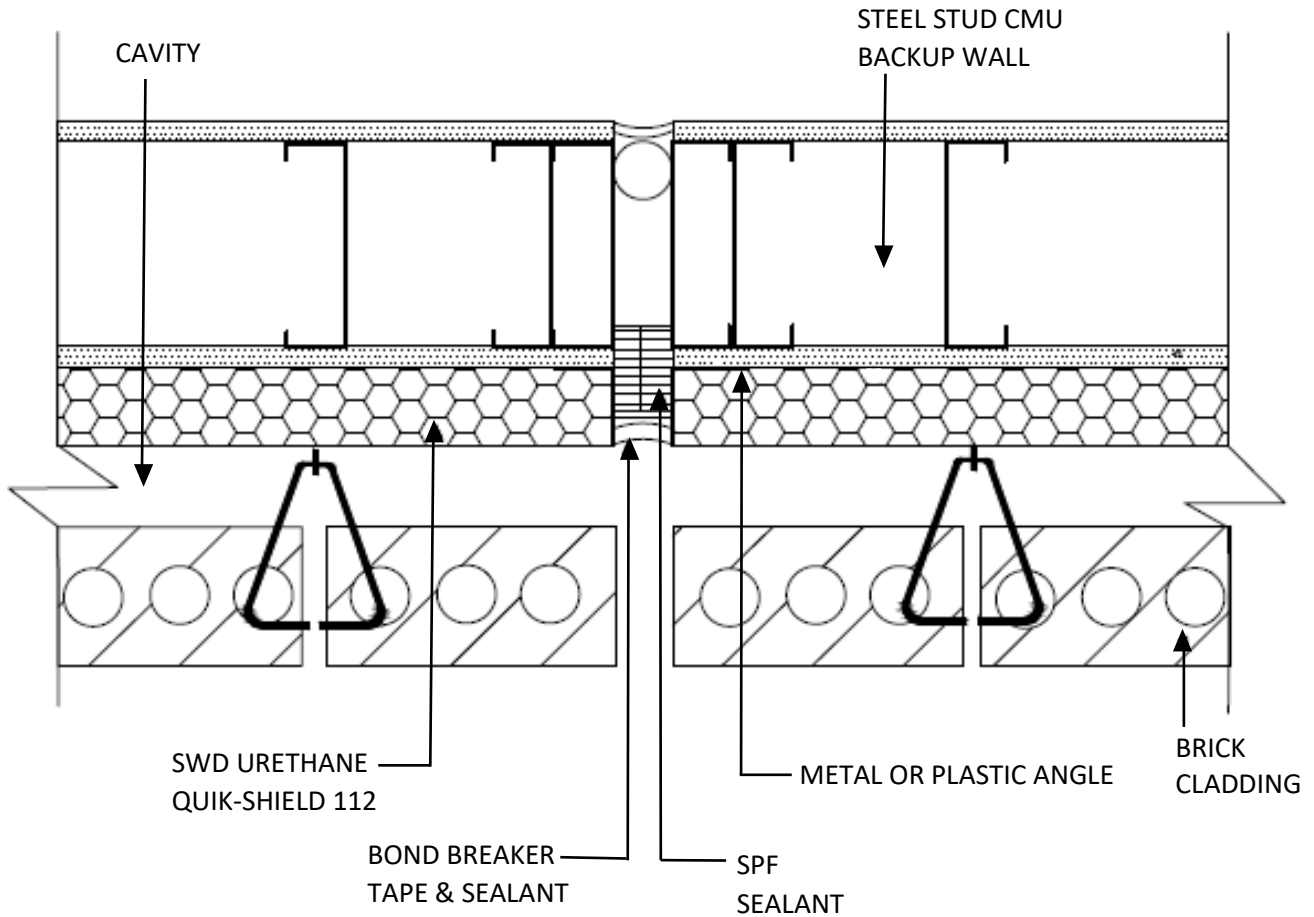

Sketch: EXPANSION JOINT	SWD Urethane 540 S Drew St. Mesa, AZ 85210	
Sketch No: 2	Date: 6/25/2018	

*DISCLAIMER – SWD Urethane is not liable for any errors or omissions in design, detail structural capability, attachment details, shop drawings or the like, whether based upon the information provided by SWD Urethane or otherwise, or for any changes which the purchasers, specifiers designers or their appointed representatives may make to SWD Urethane’s published comments. Design details are for reference ONLY.

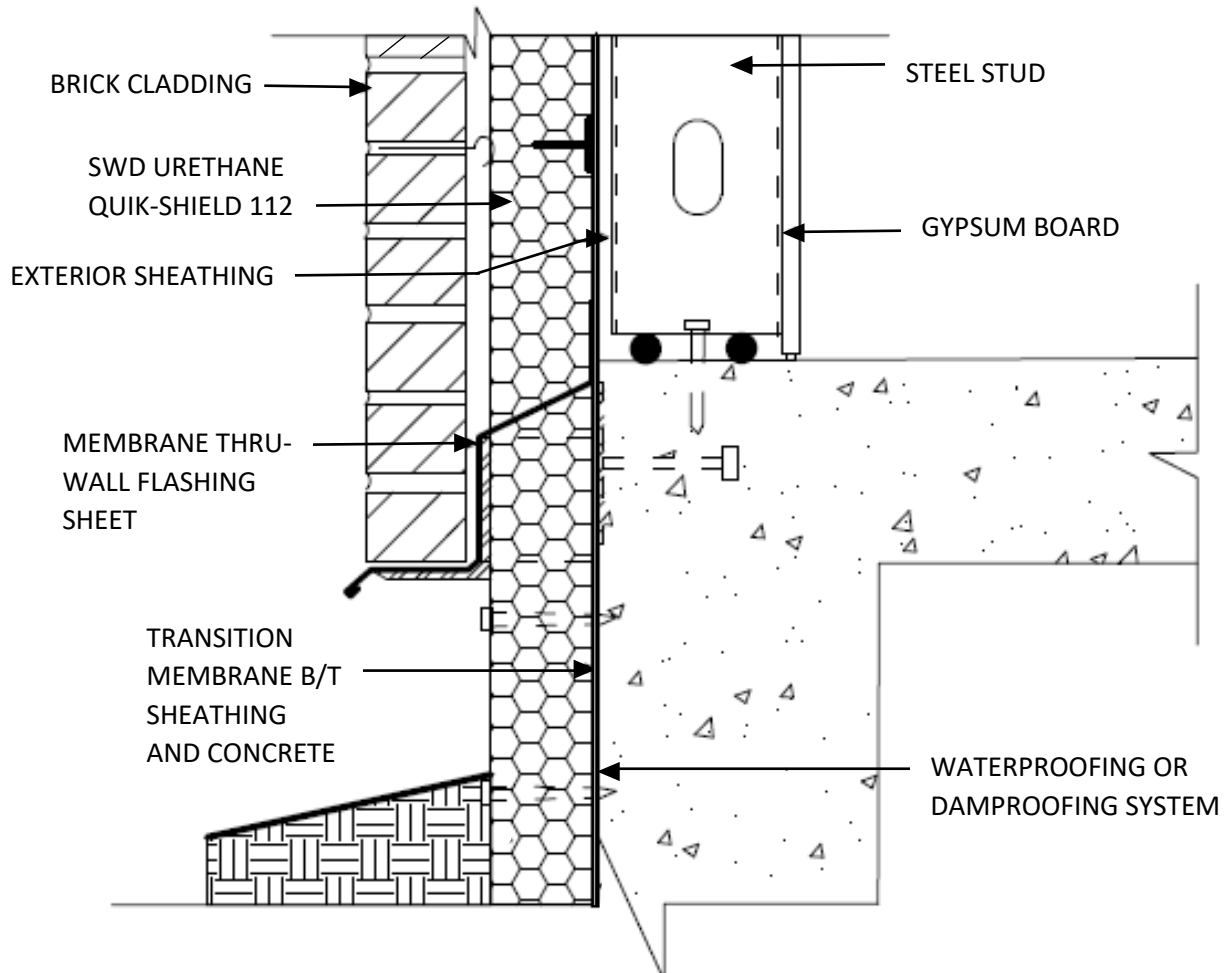

Sketch: FOUNDATION DETAIL

SWD Urethane
540 S Drew St. Mesa, AZ 85210



Sketch No: 3

Date: 6/25/2018

*DISCLAIMER – SWD Urethane is not liable for any errors or omissions in design, detail structural capability, attachment details, shop drawings or the like, whether based upon the information provided by SWD Urethane or otherwise, or for any changes which the purchasers, specifiers designers or their appointed representatives may make to SWD Urethane’s published comments. Design details are for reference ONLY.

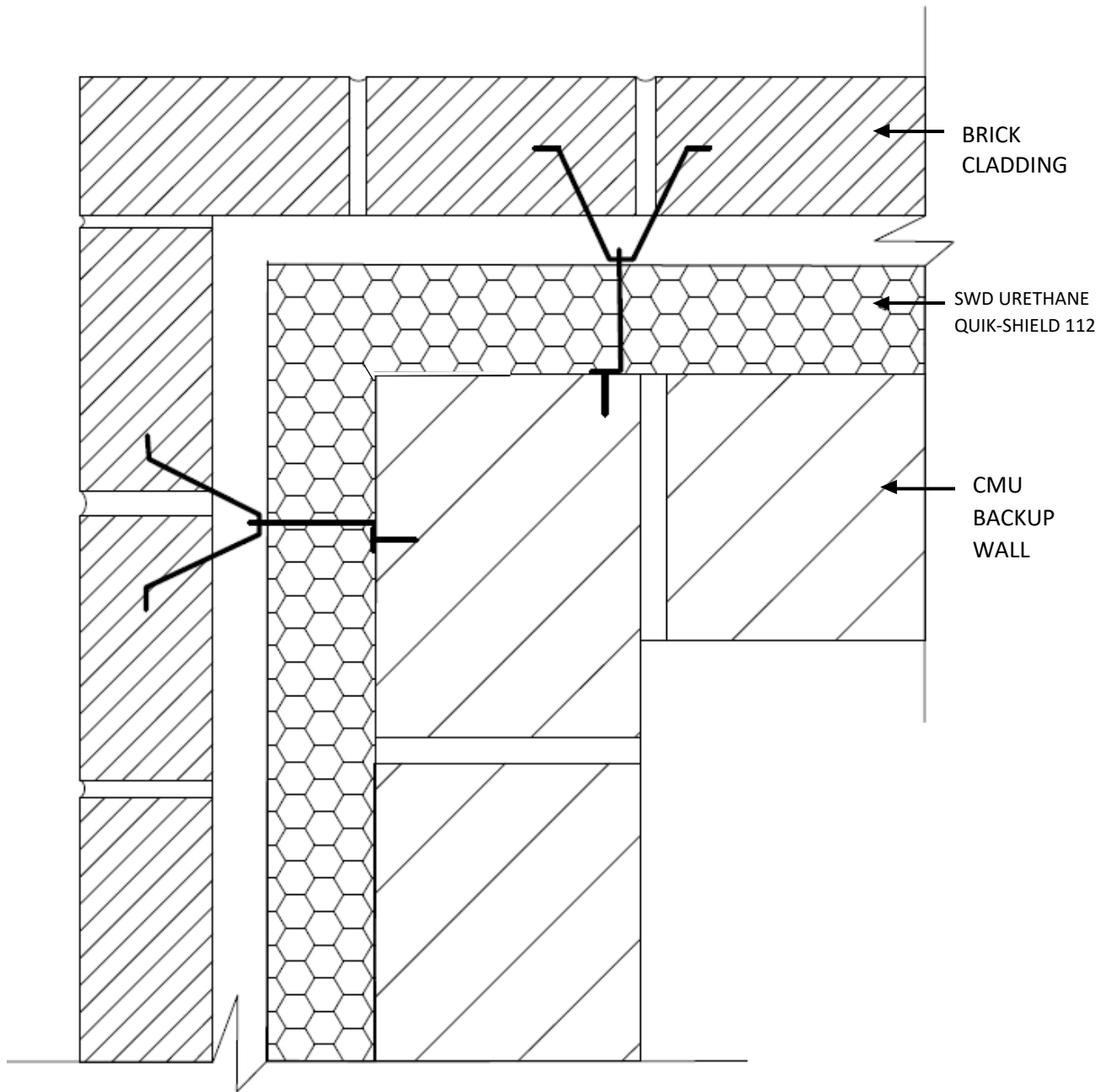

<p>Sketch: CMU CHANGE IN PLANE</p>	<p>SWD Urethane 540 S Drew St. Mesa, AZ 85210</p>	
<p>Sketch No: 4-1</p>	<p>Date: 6/25/2018</p>	

*DISCLAIMER – SWD Urethane is not liable for any errors or omissions in design, detail structural capability, attachment details, shop drawings or the like, whether based upon the information provided by SWD Urethane or otherwise, or for any changes which the purchasers, specifiers designers or their appointed representatives may make to SWD Urethane’s published comments. Design details are for reference ONLY.

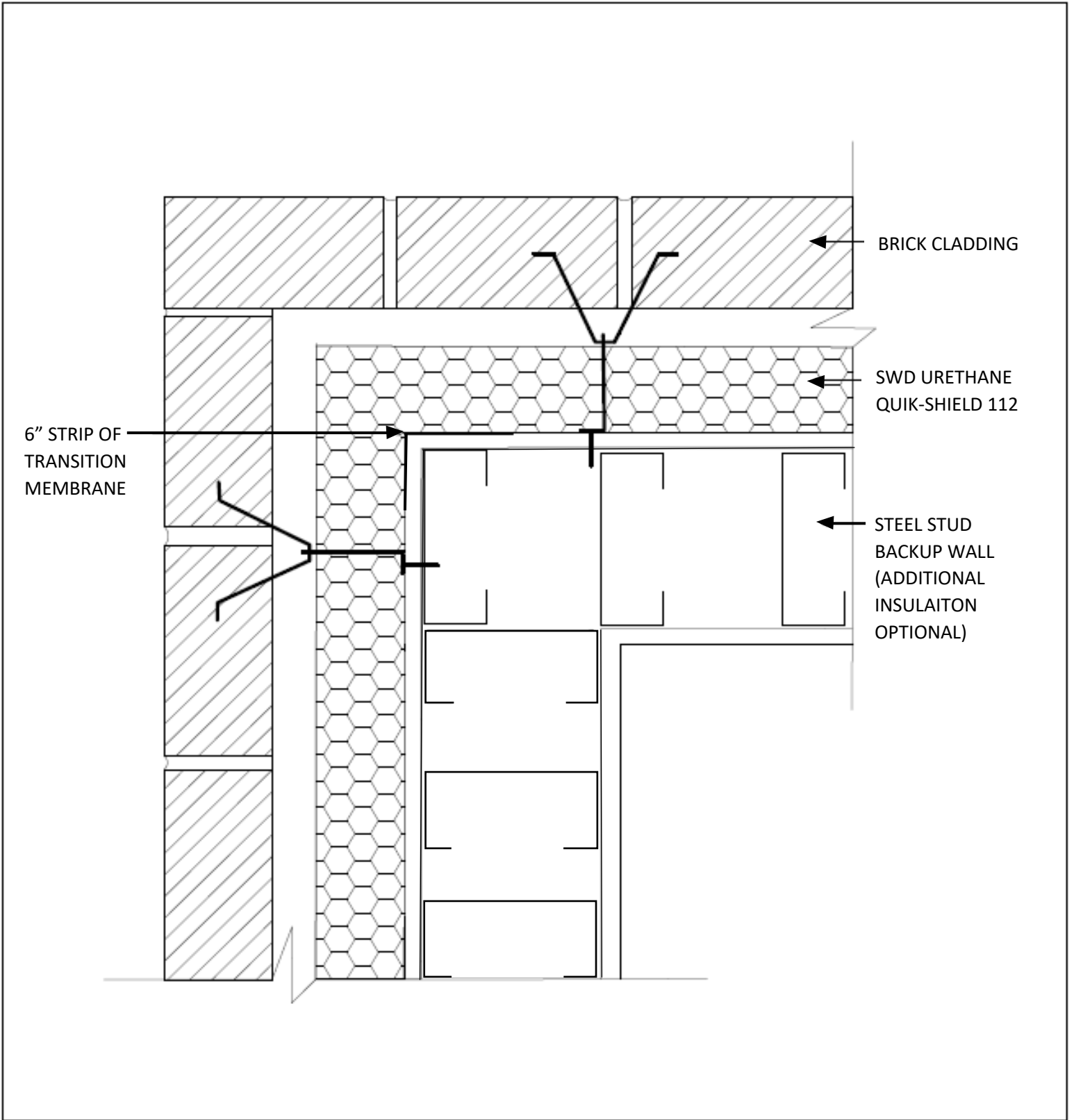

Sketch: STEEL STUD CHANGE IN PLANE	SWD Urethane 540 S Drew St. Mesa, AZ 85210	
Sketch No: 4-2	Date: 6/25/2018	

*DISCLAIMER – SWD Urethane is not liable for any errors or omissions in design, detail structural capability, attachment details, shop drawings or the like, whether based upon the information provided by SWD Urethane or otherwise, or for any changes which the purchasers, specifiers designers or their appointed representatives may make to SWD Urethane’s published comments. Design details are for reference ONLY.

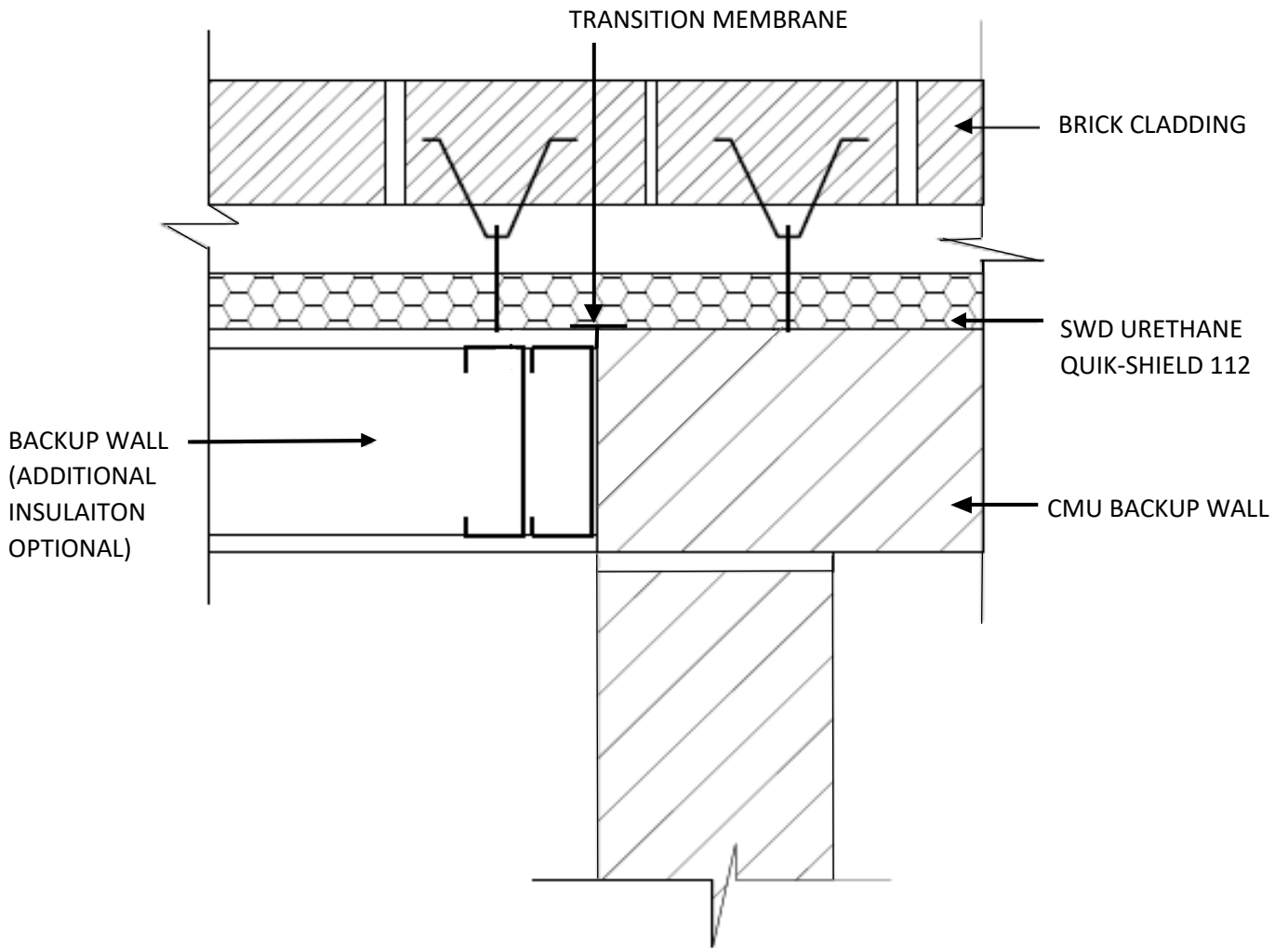

Sketch: CHANGE IN SUBSTRATE

SWD Urethane
540 S Drew St. Mesa, AZ 85210

Sketch No: 5

Date: 6/25/2018



*DISCLAIMER – SWD Urethane is not liable for any errors or omissions in design, detail structural capability, attachment details, shop drawings or the like, whether based upon the information provided by SWD Urethane or otherwise, or for any changes which the purchasers, specifiers designers or their appointed representatives may make to SWD Urethane’s published comments. Design details are for reference ONLY.

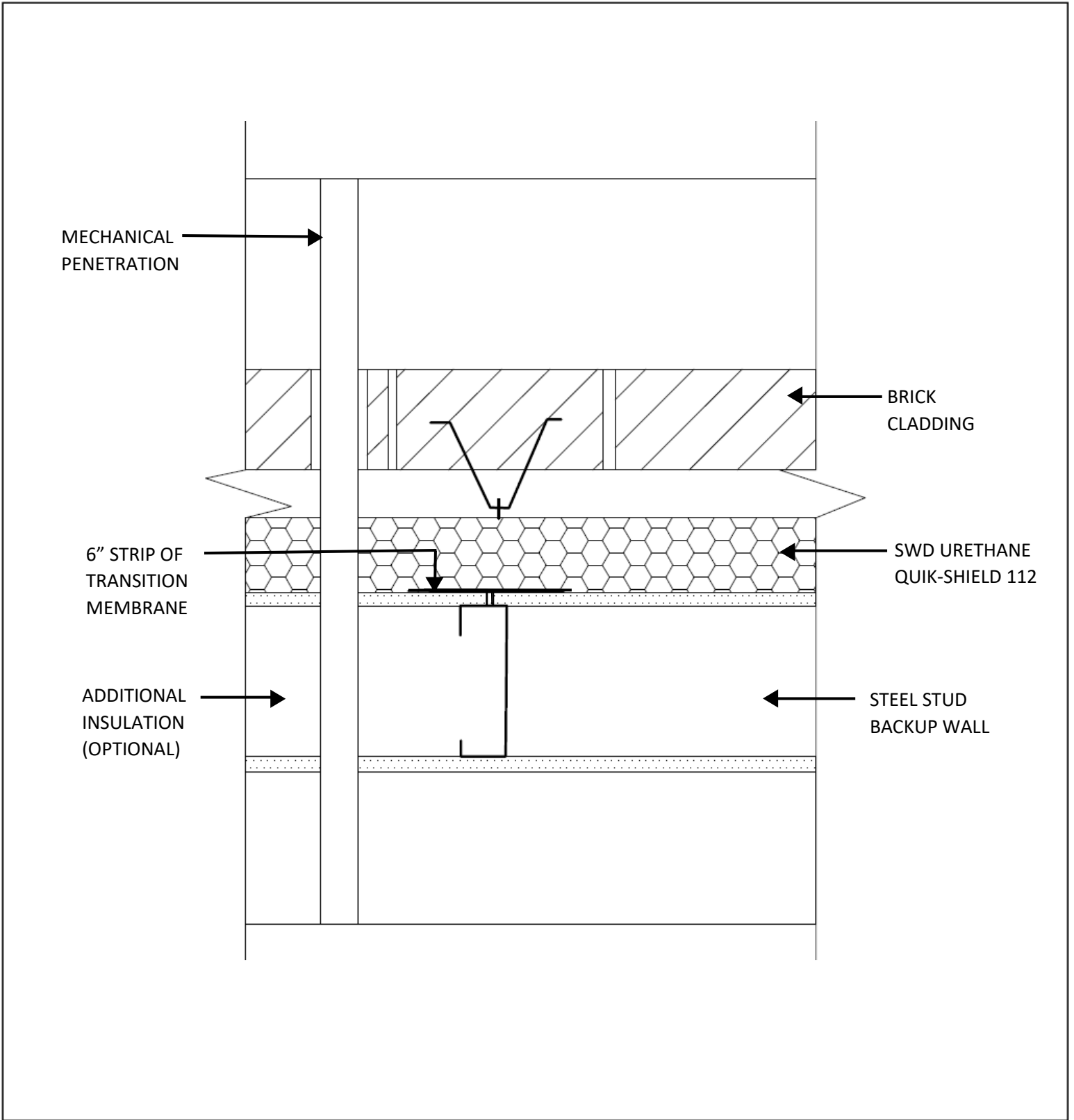

Sketch: PENETRATIONS	SWD Urethane 540 S Drew St. Mesa, AZ 85210	
Sketch No: 6	Date: 6/25/2018	

*DISCLAIMER – SWD Urethane is not liable for any errors or omissions in design, detail structural capability, attachment details, shop drawings or the like, whether based upon the information provided by SWD Urethane or otherwise, or for any changes which the purchasers, specifiers designers or their appointed representatives may make to SWD Urethane’s published comments. Design details are for reference ONLY.

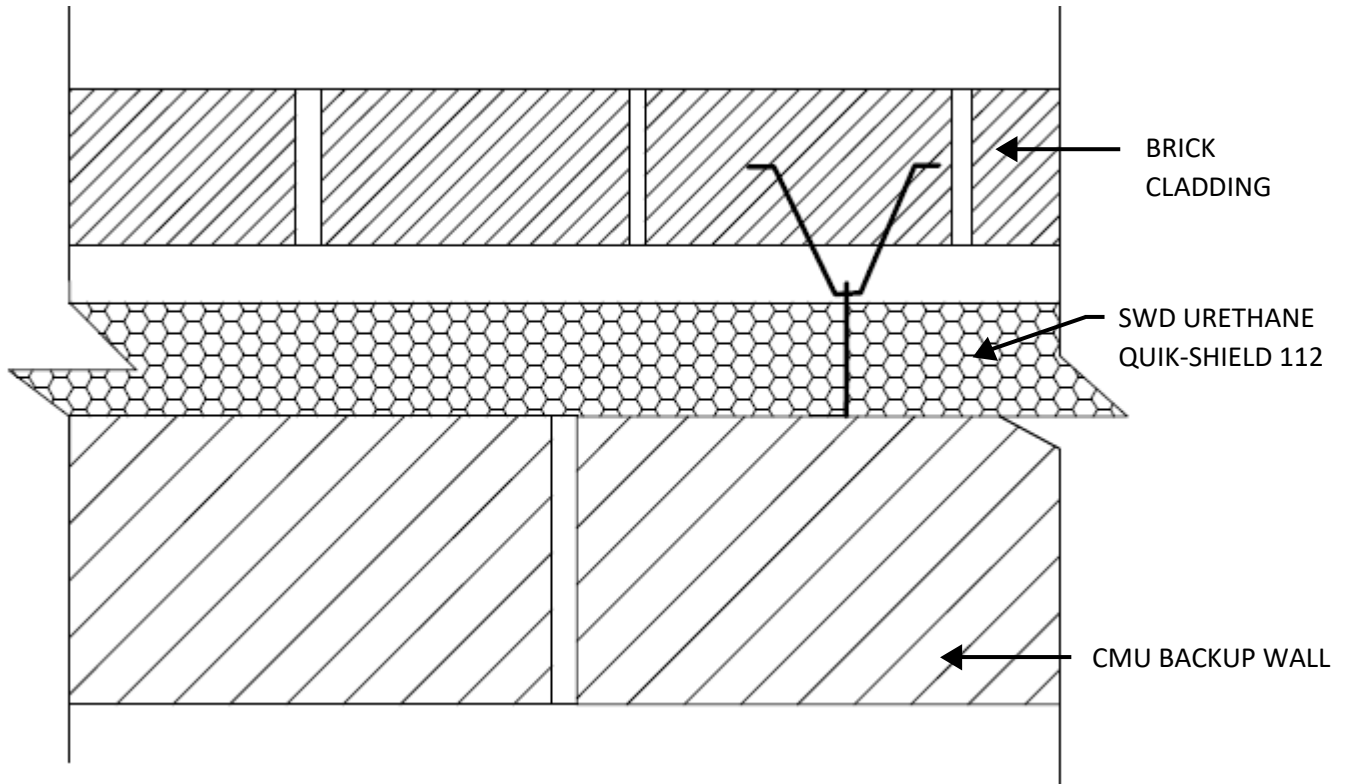

Sketch: CMU SUBSTRATE JOINT

SWD Urethane
540 S Drew St. Mesa, AZ 85210

Sketch No: 7-1

Date: 6/25/2018



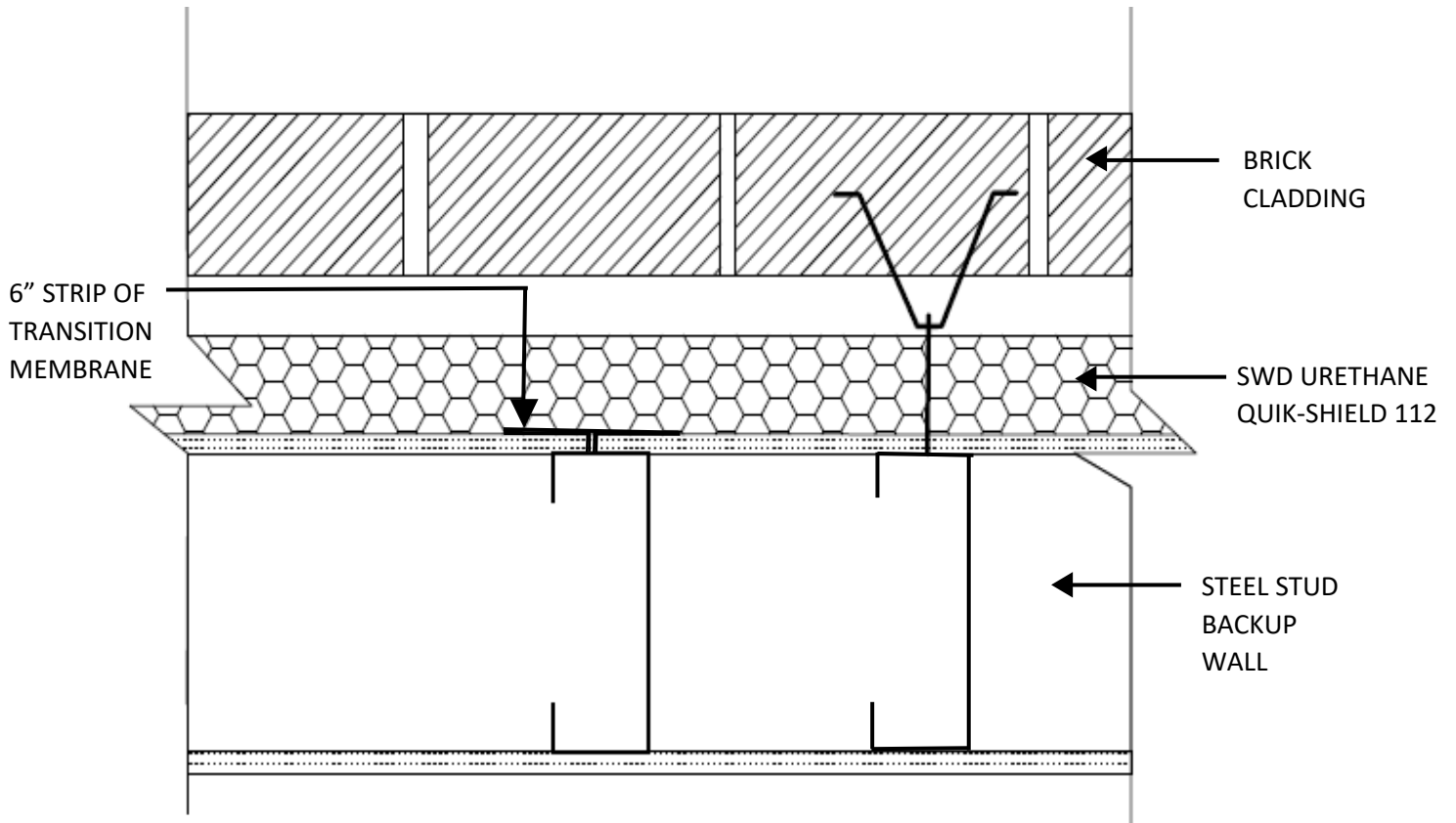

*DISCLAIMER – SWD Urethane is not liable for any errors or omissions in design, detail structural capability, attachment details, shop drawings or the like, whether based upon the information provided by SWD Urethane or otherwise, or for any changes which the purchasers, specifiers designers or their appointed representatives may make to SWD Urethane’s published comments. Design details are for reference ONLY.

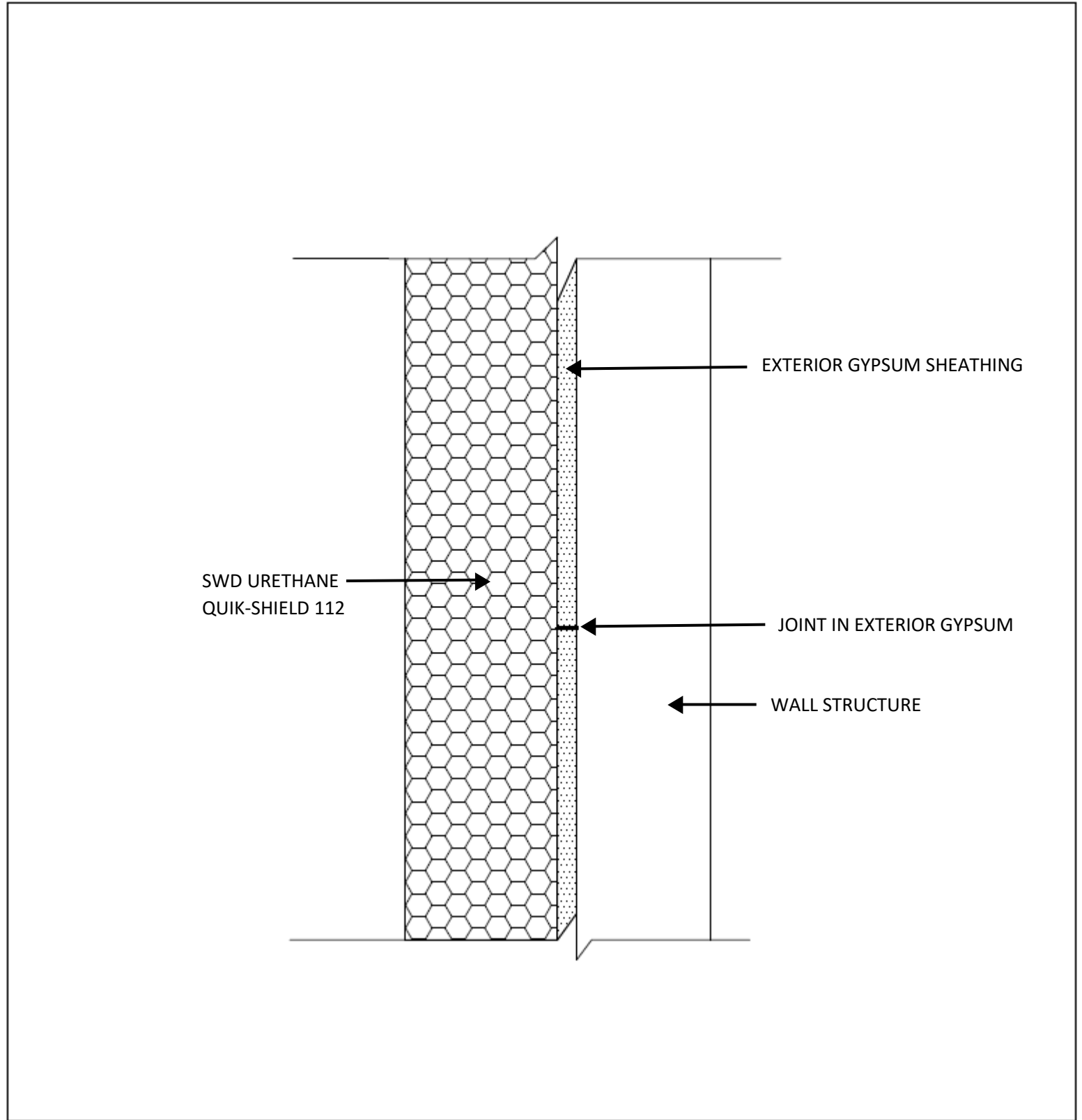

Sketch: STEEL STUD SUBSTRATE JOINT	SWD Urethane 540 S Drew St. Mesa, AZ 85210	
Sketch No: 7-2	Date: 6/25/2018	

*DISCLAIMER – SWD Urethane is not liable for any errors or omissions in design, detail structural capability, attachment details, shop drawings or the like, whether based upon the information provided by SWD Urethane or otherwise, or for any changes which the purchasers, specifiers designers or their appointed representatives may make to SWD Urethane’s published comments. Design details are for reference ONLY.



Sketch: SUBSTRATE JOINT AND DEFECT	SWD Urethane 540 S Drew St. Mesa, AZ 85210	
Sketch No: 8	Date: 6/25/2018	

*DISCLAIMER – SWD Urethane is not liable for any errors or omissions in design, detail structural capability, attachment details, shop drawings or the like, whether based upon the information provided by SWD Urethane or otherwise, or for any changes which the purchasers, specifiers designers or their appointed representatives may make to SWD Urethane’s published comments. Design details are for reference ONLY.

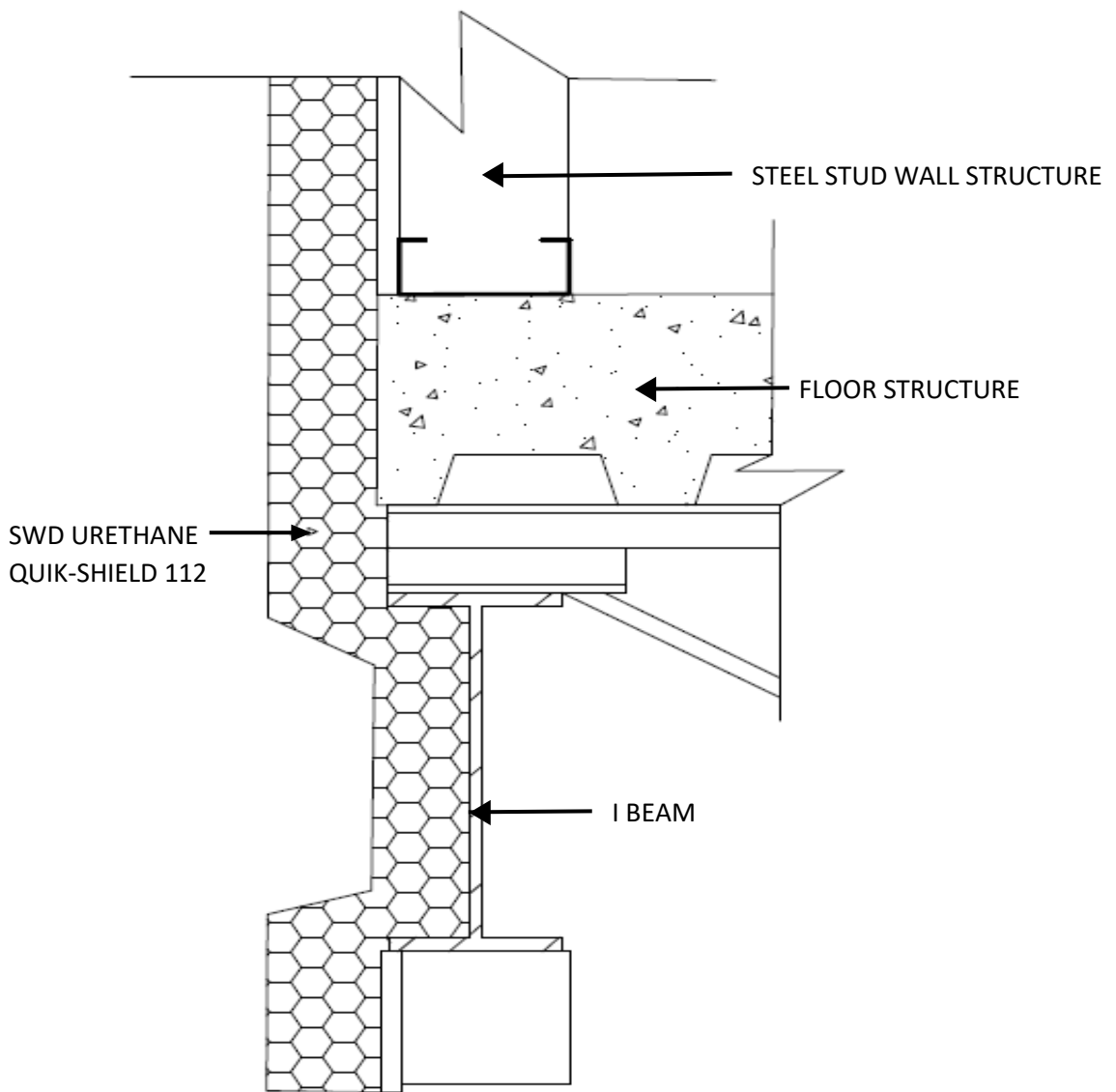

Sketch: INTER-STORY CONNECTION	SWD Urethane 540 S Drew St. Mesa, AZ 85210	
Sketch No: 9-1	Date: 6/25/2018	

*DISCLAIMER – SWD Urethane is not liable for any errors or omissions in design, detail structural capability, attachment details, shop drawings or the like, whether based upon the information provided by SWD Urethane or otherwise, or for any changes which the purchasers, specifiers designers or their appointed representatives may make to SWD Urethane’s published comments. Design details are for reference ONLY.

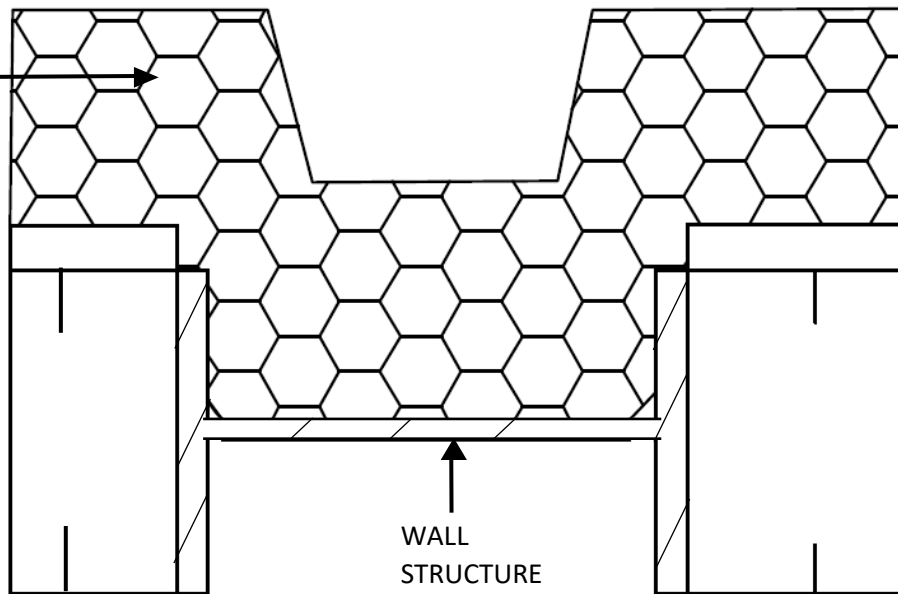

SWD URETHANE
QUIK-SHIELD 112

WALL
STRUCTURE

Sketch: INTER-STORY CONNECTION

SWD Urethane
540 S Drew St. Mesa, AZ 85210

Sketch No: 9-2

Date: 6/25/2018



*DISCLAIMER – SWD Urethane is not liable for any errors or omissions in design, detail structural capability, attachment details, shop drawings or the like, whether based upon the information provided by SWD Urethane or otherwise, or for any changes which the purchasers, specifiers designers or their appointed representatives may make to SWD Urethane’s published comments. Design details are for reference ONLY.

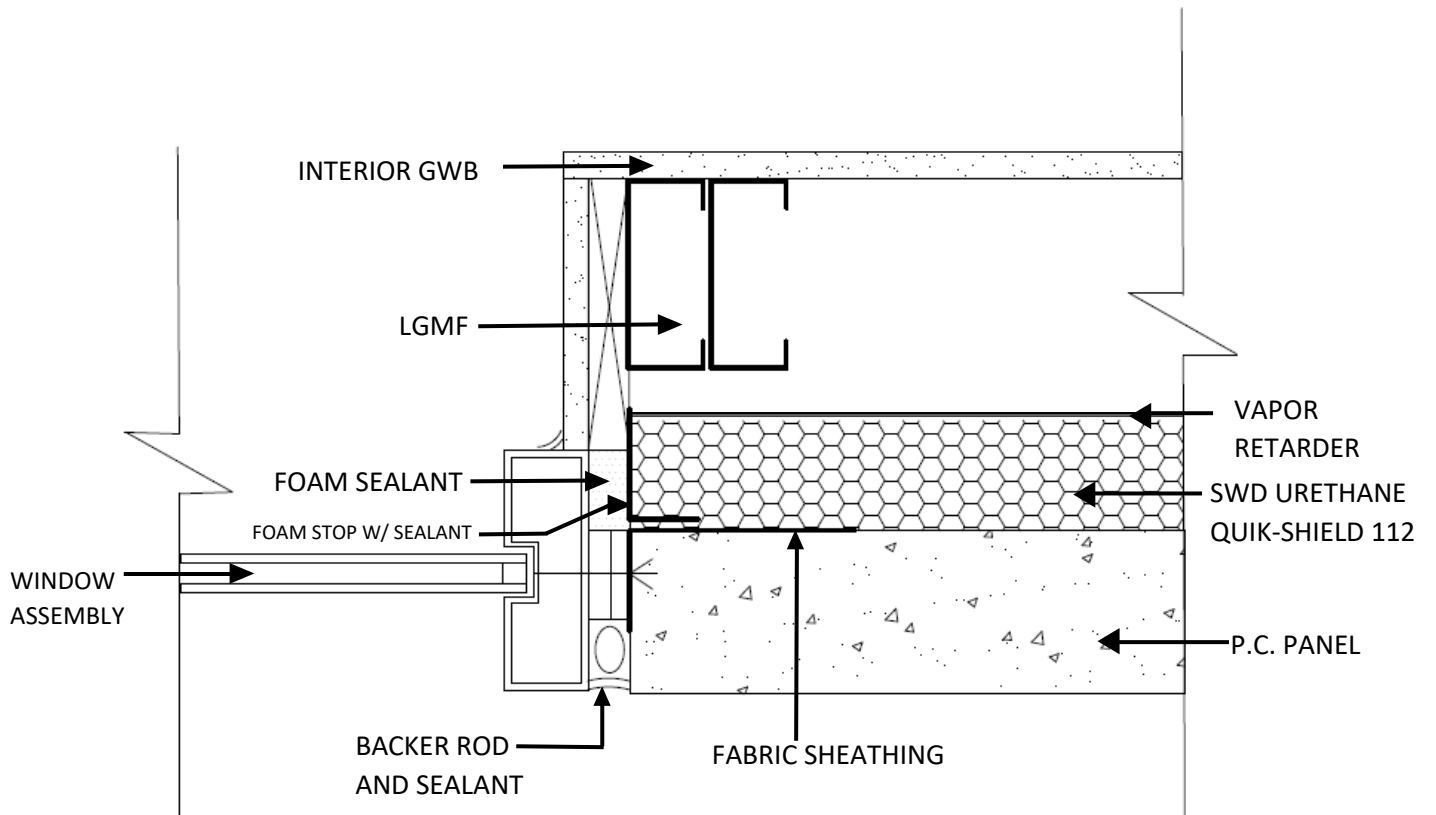

Sketch: WINDOW JAMB PRECAST PANEL

SWD Urethane
540 S Drew St. Mesa, AZ 85210

Sketch No: 10-1

Date: 6/25/2018



*DISCLAIMER – SWD Urethane is not liable for any errors or omissions in design, detail structural capability, attachment details, shop drawings or the like, whether based upon the information provided by SWD Urethane or otherwise, or for any changes which the purchasers, specifiers designers or their appointed representatives may make to SWD Urethane’s published comments. Design details are for reference ONLY.

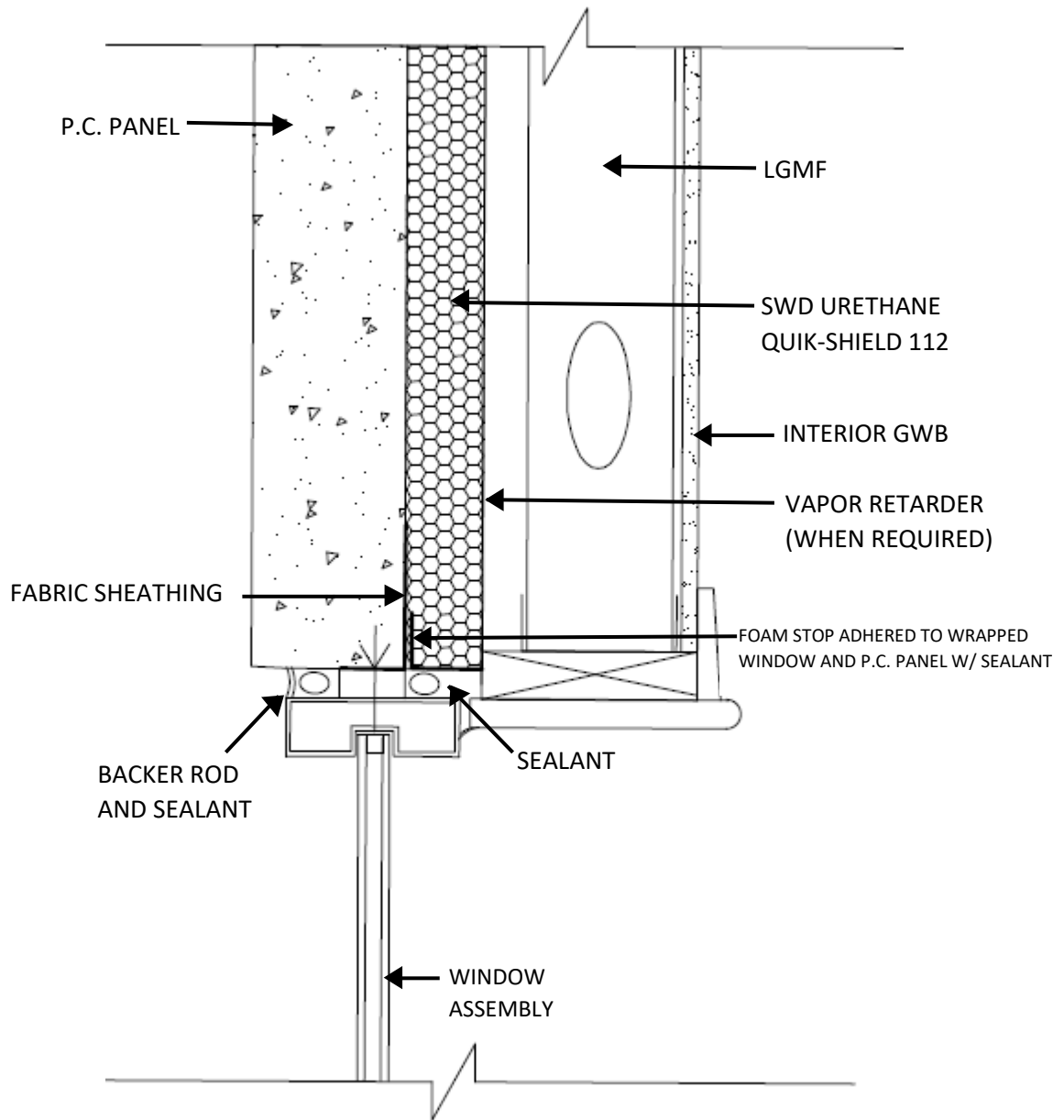

Sketch: WINDOW HEAD PRECAST PANEL	SWD Urethane 540 S Drew St. Mesa, AZ 85210	
Sketch No: 10-2	Date: 6/25/2018	

*DISCLAIMER – SWD Urethane is not liable for any errors or omissions in design, detail structural capability, attachment details, shop drawings or the like, whether based upon the information provided by SWD Urethane or otherwise, or for any changes which the purchasers, specifiers designers or their appointed representatives may make to SWD Urethane’s published comments. Design details are for reference ONLY.

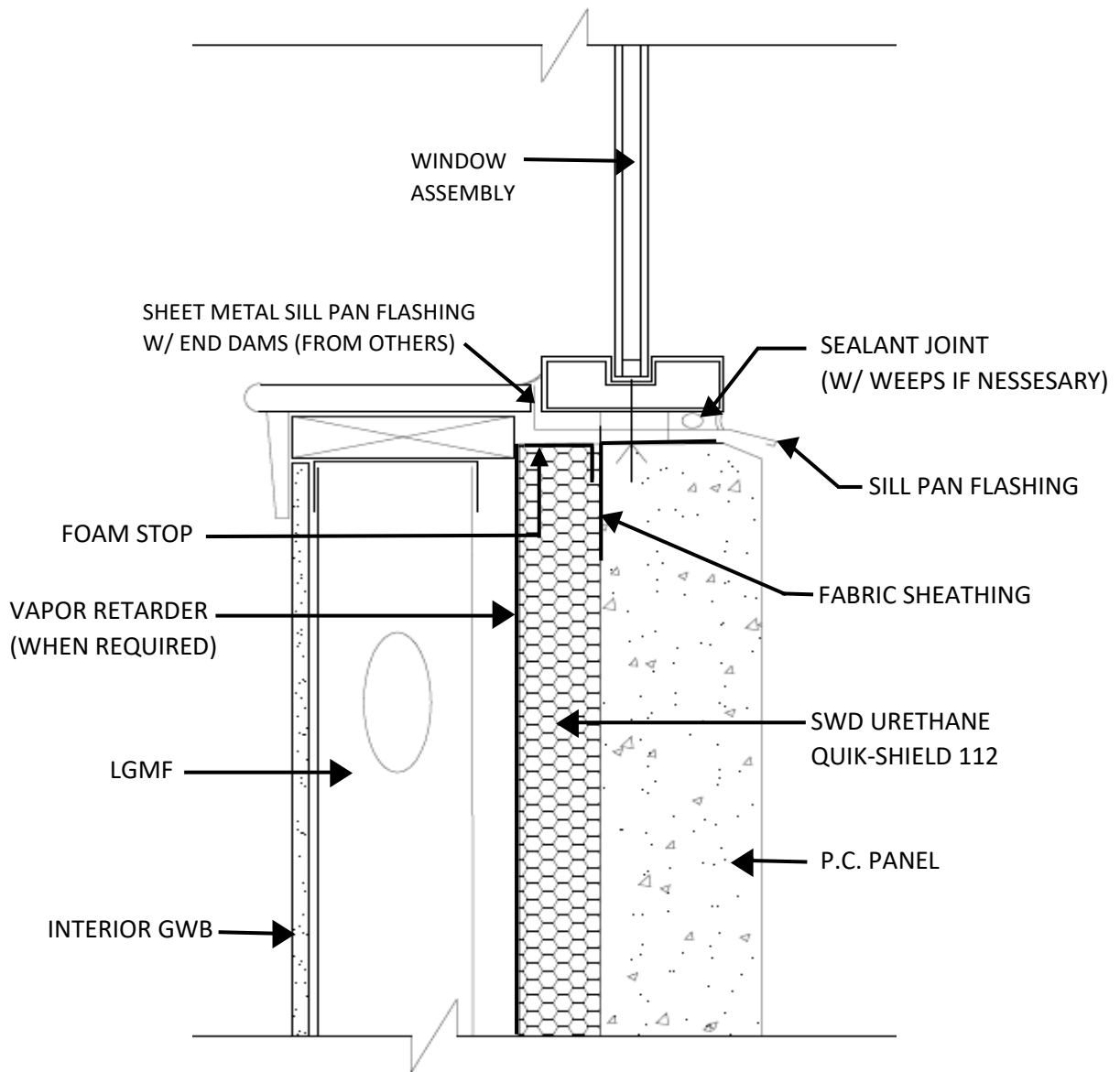

Sketch: WINOW SILL PRECAST PANEL

SWD Urethane
540 S Drew St. Mesa, AZ 85210

Sketch No: 10-3

Date: 6/25/2018



*DISCLAIMER – SWD Urethane is not liable for any errors or omissions in design, detail structural capability, attachment details, shop drawings or the like, whether based upon the information provided by SWD Urethane or otherwise, or for any changes which the purchasers, specifiers designers or their appointed representatives may make to SWD Urethane’s published comments. Design details are for reference ONLY.

NOTE: IF BLOCKING IS NOT PRESENT AT TIME OF SPRAY FOAM AND AIR BARRIER INSULATION, WRAP MEMBRANE OVER METAL ANGLE.

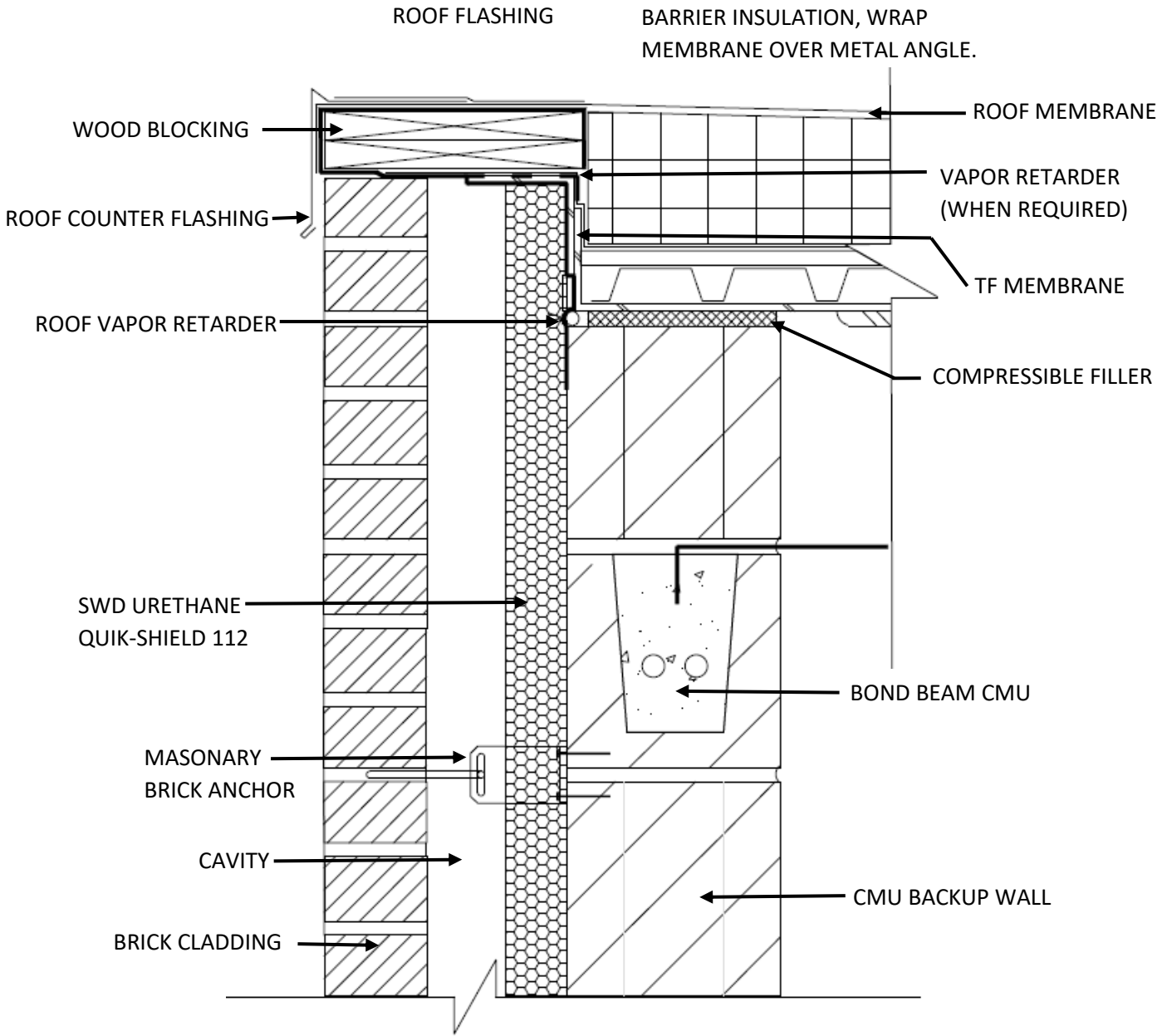

<p>Sketch: CMU BACKUP ROOF DETAIL</p>	<p>SWD Urethane 540 S Drew St. Mesa, AZ 85210</p>	
<p>Sketch No: 11</p>	<p>Date: 6/25/2018</p>	

*DISCLAIMER – SWD Urethane is not liable for any errors or omissions in design, detail structural capability, attachment details, shop drawings or the like, whether based upon the information provided by SWD Urethane or otherwise, or for any changes which the purchasers, specifiers designers or their appointed representatives may make to SWD Urethane’s published comments. Design details are for reference ONLY.